

GENERATOR FIRE:

the experience, the repair, and the prevention

Ed Gurdjian and Carol Maxwell
RvTechStop.com October 2007

We had traveled to Michigan from our home in Pennsylvania to enjoy a long weekend visiting friends and family. On Sunday morning, Ed arose first and began his daily ritual of recording energy statistics. He realized that the battery bank was becoming discharged and planned to start the generator. Before he could do so, the generator started by itself. Ed thought that was odd because he was sure he had not enabled the inverters' auto-start program. Nonetheless, he started the chargers and turned on the coffee. By that time, I was up and working on my daily chores of taking care of our pets' needs. Then, as unexpectedly as it started, the generator shut down. While Ed was trying to analyze these events, I noticed the smell of smoke. Both of us quickly went outside. Since Ed thought the problem was with the inverters, he opened the inverter compartment first. There was no problem there, so we went to the

compartment that houses the radiator for the generator. Still, there was nothing amiss. Next we opened the generator compartment. Smoke poured out and, with the influx of air, flames erupted. I ran to get the fire extinguishers, which we always carry and are careful to make sure they are fully charged. Lucky for us, Ed was able to quickly put out the fire!

We were very fortunate to have avoided a catastrophe. One day later, we were away from the coach for over 12 hours. If the incident had happened then, we feel certain that the coach would have been burned to the ground. The disaster would have included not only the loss of the coach, but also our beloved pets. In addition, we had been living in the coach for over a year and all our personal records were with us. Every time a fortunate outcome results from a potential disaster, we consider ourselves extremely lucky. Since we may not be as lucky the next time, we

With components from **Digi-Key** and **J&N Auto Electric**, the authors have installed a protective circuit to reduce the possibility of a generator fire secondary to multiple electrical component failures, and specifically, starter run-on.

are driven to find a solution to prevent the problem from ever occurring again.

After we put out the fire, Ed heard an electrical hum in the control box of the generator. Opening the box, he could not tell which relay was humming. The wiring was still intact. He disconnected the battery cable to turn off all DC voltage to the generator, and finally, the hum stopped. Fire retardant from the fire extinguisher was everywhere. The generator air bags were collapsed. The vents around the stator housing were discolored from smoke and perhaps flames. At this point, Ed thought the generator, and not the engine, had burned.

Since our coach does not have a sliding tray for the generator, we could not view the inboard side of the generator without unloading the compartment on the opposite side. We had a very important appointment the next day and did not want to get involved in a project of this magnitude. After carefully checking to make sure that there was no danger of a recurrence from a stray power source, we decided to address the problem upon our return home several days later.

Upon arriving home, we unloaded the storage compartment on the passenger side, and removed the access panel, which allowed us to view the inboard side of the generator for the first time. The starter was “toast.” For a length of

six to eight inches, insulation had been burned off the sense wire to the alternator and the wire to the high temperature switch. At one point, these two wires were fused together. One of the air lines to the air bags had a hole in it. At this time, Ed wondered if the first event was the collapse of the air bags which could have hindered ventilation causing an overheat condition. Later,

and starter drive appeared undamaged.

Obtaining a replacement starter proved to be the most difficult part of the repair. We faced poor information, documentation, and support from Kubota; and excellent support, but outrageous policies, from Nippon-Denso, the manufacturer of the starter. The original starter was rated at 2 kW, but the current replacement is

The described modifications can be applied to generators in renewable energy systems or residential back-up systems , as well as the described motorhome electrical system.

he determined that the air line had been hit by molten lead from the sound insulation that had been so hot that it flowed like solder. Some of the lead had dripped onto the air line and perforated the wall. We temporarily repaired the air line and then inflated the air bags. They were intact and did not leak—hooray! This elevated the generator off the floor and allowed us to remove the sound insulation, which was covered with fire retardant. Once the insulation was out, we were able to pressure wash the generator and compartment—what a messy job. With difficulty, Ed removed the starter. The armature was fused to the field coils, but interestingly, the solenoid

rated at 1.4 kW. The reason for this and whether or not it was important, Nippon-Denso couldn't say and Kubota wasn't talking. Apparently, Kubota initiated the change from 2 kW to 1.4 kW. We surmise that a smaller size and less powerful starter would cost less to manufacture, but could not find any other explanations for it.

At this stage, we still had no idea as to the extent of damage. We did not know if either the motor or the generator was serviceable. After searching for days, we found what might be an exact replacement starter. Unfortunately it was in Australia. Determined to find one a little closer to home, we kept searching. Finally,

Nippon-Denso California technical support provided blueprints and specifications for all of the starters. We had to do a little extrapolation because some of the captions were in Japanese! The cost of a new starter was \$350 from the Nippon-Denso distributor in California. The cost of a rebuilt one was \$200, with a replacement core. After careful review of the specs, Ed chose a rebuilt unit.

While waiting for the starter to arrive, Ed repaired the burned wiring, the damaged air line, and cleaned, but did not install, the compartment insulation. When the starter arrived, everything else was ready. The good news was that the starter was actually a new unit, labeled as rebuilt. He also learned, to his dismay, that a core was only acceptable for credit if it was undamaged. Thus with no core credit, the cost was \$240, not including shipping. The second good news was that the starter installed without difficulty.

Now, the test began. We started the generator engine and the generator produced proper AC voltage and frequency. Because we wanted to run the generator for as short a time as possible, we did not do load testing. When we tried to turn the generator off, rpms dropped as if it was going to shut off, but on releasing the stop button, Ed heard the starter cranking. Engine rpms then increased and the generator continued to run. Ed had to disconnect battery

power to stop the generator. Because of the engine noise, we could not determine if the starter had been running all the time, but it was quite warm to touch. Ed then disconnected the autostart wiring. We restarted the generator and it ran fine, but it would still not stop the way it should. However, this time Carol kept her hand on the starter to monitor temperature while the generator was running so it appeared that the starter was not continuing to run-on as it had the first time. Ed again disconnected battery power to stop the generator. After studying the wiring diagram

Since generators from various manufacturers may be wired differently than those shown here, it may be necessary to adapt the modifications to the specific diagram. The latching solenoid to cut B+ from all generator circuits, the Klixon thermal switch, and thermometers should be readily adaptable to most, if not all, generators.

(FIG 1) he decided to attempt to stop the generator by disconnecting the sense line from the alternator, surmising that the alternator sense line was back feeding 12V. Normally, the alternator regulator has a

diode to prevent such backfeeding. When he disconnected the alternator line, the generator stop-switch worked normally. Next he inserted an external diode in the alternator sense line where it was connected to the fuel rack solenoid. The generator then appeared to function normally with the sense line intact. Ed was not sure when the diode in the alternator regulator failed, but over the previous year or two, we had experienced several episodes of generator failure to turn off when the manual “off” switch was activated soon after startup. This was a rare occurrence and seemed to correct itself if the generator was allowed to come up to temperature, but Ed was never able to identify the reason for the problem. Also, in retrospect, the generator battery may have been discharging more than it should have during periods of disuse. These last two factors suggest that there may have been a chronic problem with the diode isolating the sense line from the battery.

Ed was still uncertain about what caused the problem. When he installed new inverters a few years ago, he re-wired the generator to enable the inverter autostart system, which disabled the protection against starter run-on contained in the original wiring. The original genset wiring included two

switches; one to activate the glow plugs (pre-heat), and one for generator ON and OFF (FIG. 1) The first switch is a single-pole-single-throw momentary normally off, the second is a single-pole-double throw momentary center off, and both toggle to ground. The autostart circuit has only two relays. One is used for glow plug activation and the other for starter activation. There is no separate “OFF” relay, so that function is incorporated into the glowplug relay. Combining the glow plug and OFF function into one relay required that the protection afforded by the separate glow plug switch in our application had to be disabled. Ultimately, rewiring the generator to make it compatible with this particular autostart system allows the starter solenoid to run-on if the starter relay becomes stuck for any

reason. In retrospect, he should have installed an extra relay similar to that seen in Figure 2 to maintain protection against starter run-on. That relay would have disconnected battery voltage to the starter solenoid whenever the relay detected AC. This protection system would have failed, however, if the generator had ever failed to produce AC while the engine was running or the start relay contacts became fused, which would have continued to supply B+ to the starter solenoid. Ed was frustrated with being unable to determine the exact sequence and cause for the fire. However, he was determined to design a safety circuit that would eliminate the possibility of this ever happening again, whatever the cause. He recognized that even with no autostart system at all, there was still a possibility for starter run-on, which could result in a

catastrophic fire. First, he studied two frequently used wiring plans as shown in Figures 1 and 2. Figure 1 uses two switches, which are described above. Figure 2 uses a double-pole-double-throw momentary center off switch, where one pole toggles to ground and the other to 12 VDC. Figure 1 provides 12 VDC to the starter relay only when the glow plug relay is activated, thus offering protection against inadvertent activation of the starter which would allow starter run-on. Figure 2 uses an extra relay detecting the presence of AC to prevent starter run-on. Although each generator manufacturer may have minor variations, their schematics will generally have four or five relays and two or three switches. Some auto-start circuits may require only three relays. He also reviewed the gauges and protection circuits used

<i>DIAGNOSTIC GAUGES</i>	<i>LED INDICATORS</i>	<i>PROTECTION DEVICES</i>	<i>CONTROL RELAYS</i>	<i>12VDC REQUIRED</i>
Hour Meter	Generator run signal	Low oil pressure sensor	Shutdown	Starter
Coolant temperature	High temperature	High coolant temperature sensor	Start	Fuel rack solenoid
Oil pressure	Low oil pressure	Low coolant level sensor	Pre-heat	Fuel pump
Fuel	Battery ON	Low oil level sensor	Over-temp	Alternator sense line
AC voltmeters (L1, L2)	AC present signal	Starter high temp thermal switch	Starter lockout	
AC ammeters (L1, L2)	Starter cranking signal			
Hertz meter	Overspeed			

TABLE I

to obtain generator diagnostic information. Many of us remember early coaches that had generators with no AC, DC, or motor gauges. However, once one has owned a coach with extensive generator monitoring equipment, it is hard to go back.

As shown in Table I, premium installations by many coach manufacturers have an hour meter, engine coolant temperature, oil pressure, fuel level, and generator battery voltage. In addition, AC diagnostic gauges include AC voltmeters (analog or digital) for L1 & L2, AC ammeters (analog or digital) for L1 & L2, and a Hertz meter for L1 and L2. Most manufacturers install sensors for low oil pressure and high coolant temperature as protection devices. Less frequently seen are sensors for low coolant level and low oil level. As far as we could determine, starter high-temperature thermal switches have not been employed. Generator control systems usually have four or five relays. These include a preheat relay, a start relay, a shutdown relay, sometimes referred to as an oil pressure relay, a coolant temp relay (over temp/shutdown) and a starter lockout relay. In the wiring diagram shown in Fig. 1, note that 12 VDC is required for the starter, fuel rack solenoid, fuel pump, and alternator sense line.

After carefully reviewing the wiring diagrams and the protection devices referenced

above, it seems that additional protection may be afforded by the options listed below with locations shown on Figure 3.

Option 1: Use a latching solenoid for powering and de-powering all generator circuits. This manually disables the autostart function and the generator.

Option 2: Place a low amperage fuse in the B+ line to the solenoid. I believe this is a standard protection device in marine applications.

Option 3: Use a wiring protocol that permits B+ to the starter solenoid relay only under limited circumstances such as only when the glowplug relay is activated. Alternatively, use a starter lockout relay that locks out any B+ to the solenoid whenever AC is being generated. In both cases a sticking relay could still cause problems.

Option4: Use a Klixon type of thermal switch on the starter. This option will prevent extraneous B+ to the starter solenoid from causing starter run-on once the starter case becomes heated. However, it will not prevent starter run-on if the solenoid contacts become fused. To eliminate this rare possibility, the Klixon can be interfaced to a circuit which will trip the latching solenoid supplying B+ to the generator, thereby cutting power to all generator circuits, including the starter.

Option 5: Use thermometers to monitor the temperature of the generator compartment and the starter case. Figure 4 shows the location of circuits for diagnostic LEDs, thermometers, and an ON/OFF latching solenoid for 12V supply. On our coach, a red LED indicates the starter is cranking, a yellow LED indicates the



generator is running and AC is being produced, and a green LED indicates that battery power to the generator is enabled.

Modifying the wiring to add the new circuits will vary in different vehicles. However, in most cases, existing wiring will be modified on the generator, at the generator battery, in the generator control box, and at the remote panel inside the coach. New wires will be added between the generator compartment and the interior control panel. The LEDs, resistors, the momentary switch, and the thermometer display are installed on the control panel. The latching solenoid is installed next to the generator battery on the positive line out of the battery and after the auxiliary start solenoid (jump-start or booster solenoid), if so equipped. The new momentary push-button switch on the control panel controls the latching solenoid. The Klixon is installed directly on the starter case and held in place with a wire or nylon strap. The existing battery cable supplying the starter is moved to one terminal of the normally closed solenoid and a new cable is installed from the solenoid to the starter. One temperature sensor is installed on the starter case and the other is installed in an appropriate location to monitor ambient air temperature.

Since we continue to be very apprehensive about the generator operating when we

are away from the coach or while sleeping, we always disconnect the 12V supply with the ON/OFF latching solenoid. We understand that those with all-electric coaches that require continuous power to run high consumption appliances such as residential refrigerators may not always be able to use this option, but it may be useful when the coach is in storage.

We were never able to determine whether the starter run-on was a primary problem or if it was caused by a sticking auto start relay or a sense line diode failure. However, the protection features we describe are designed to protect against starter run-on regardless of the cause. Others may view our approach too complicated and we might have been inclined to feel that way, too, if we had not experienced the fire. For those, simply installing the latching relay and verifying that their primary generator wiring contains one of the circuits of Option 3 listed above, may offer enough protection. Nonetheless, our commitment is to do whatever it takes to unequivocally eliminate any possibility of a repeat episode. We hope our experience and some part of our solution will help others to avoid a similar problem.

Parts list:

Latching solenoid and normally closed solenoid available from J&N Auto Electric,

www.jnelectric.com
800-366-7100.

Electronic parts available from Digi-Key,
www.digikey.com
(800-344-4539).

1 Latching relay solenoid
1 Solenoid, normally closed
3 LEDs, T 1 3/4
 Red
 Yellow
 Green
3 LED holders, T 1 3/4
3 620 ohm/1/2 watt resistors
1 SPST momentary normally off switch
1 20 amp 3AG fuse
1 3AG fuse holder
1 thermal switch, 70° C
1 120 VAC ice cube relay
DPDT
1 Relay socket
1 Dual channel thermometer
Category 5 wire as required
16 g wire as required

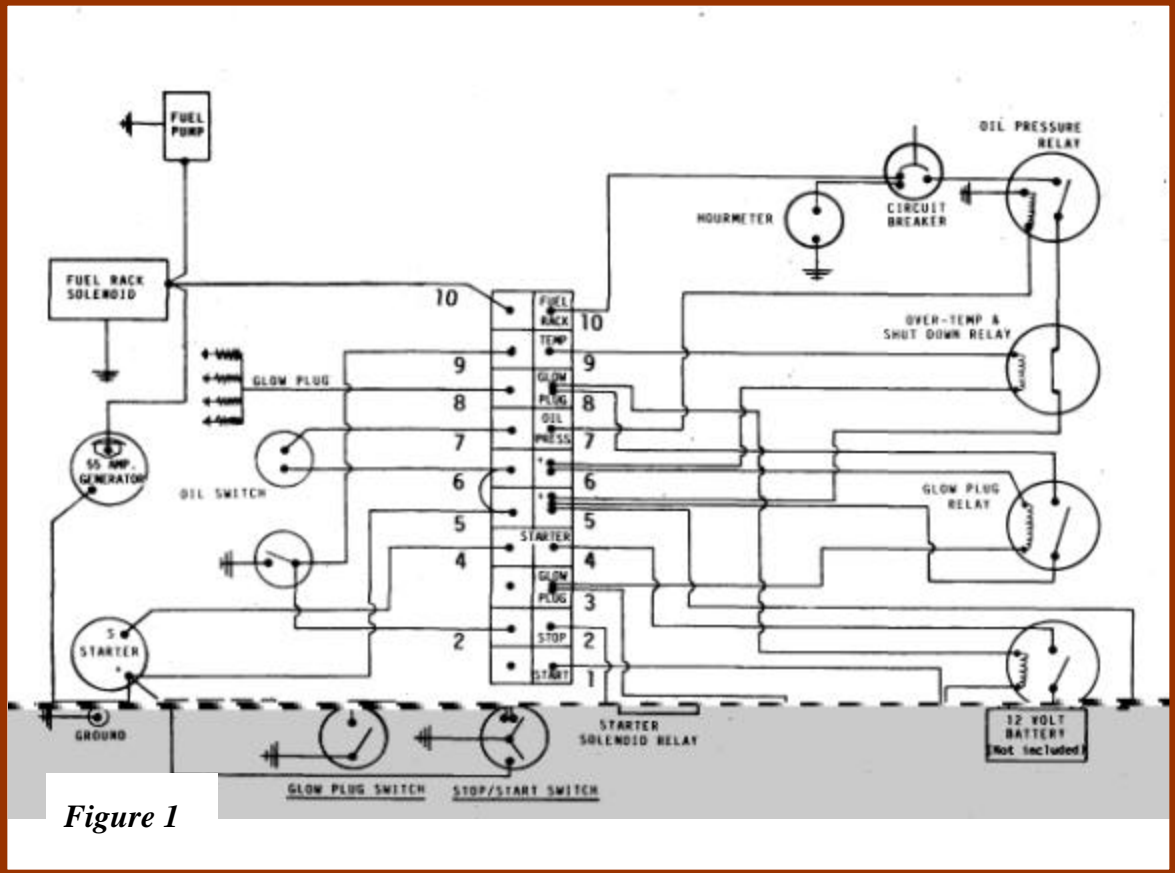

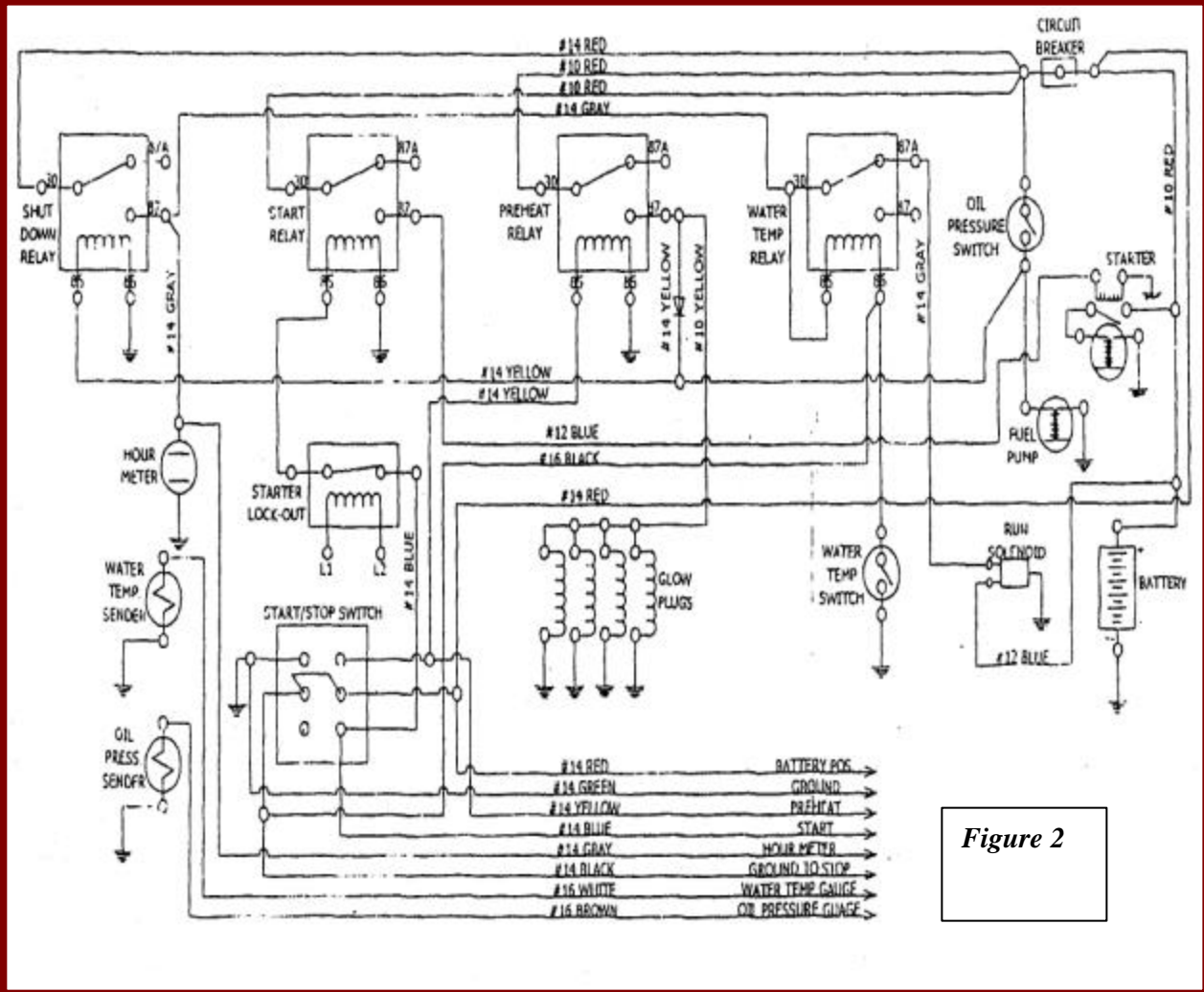

Figure 2

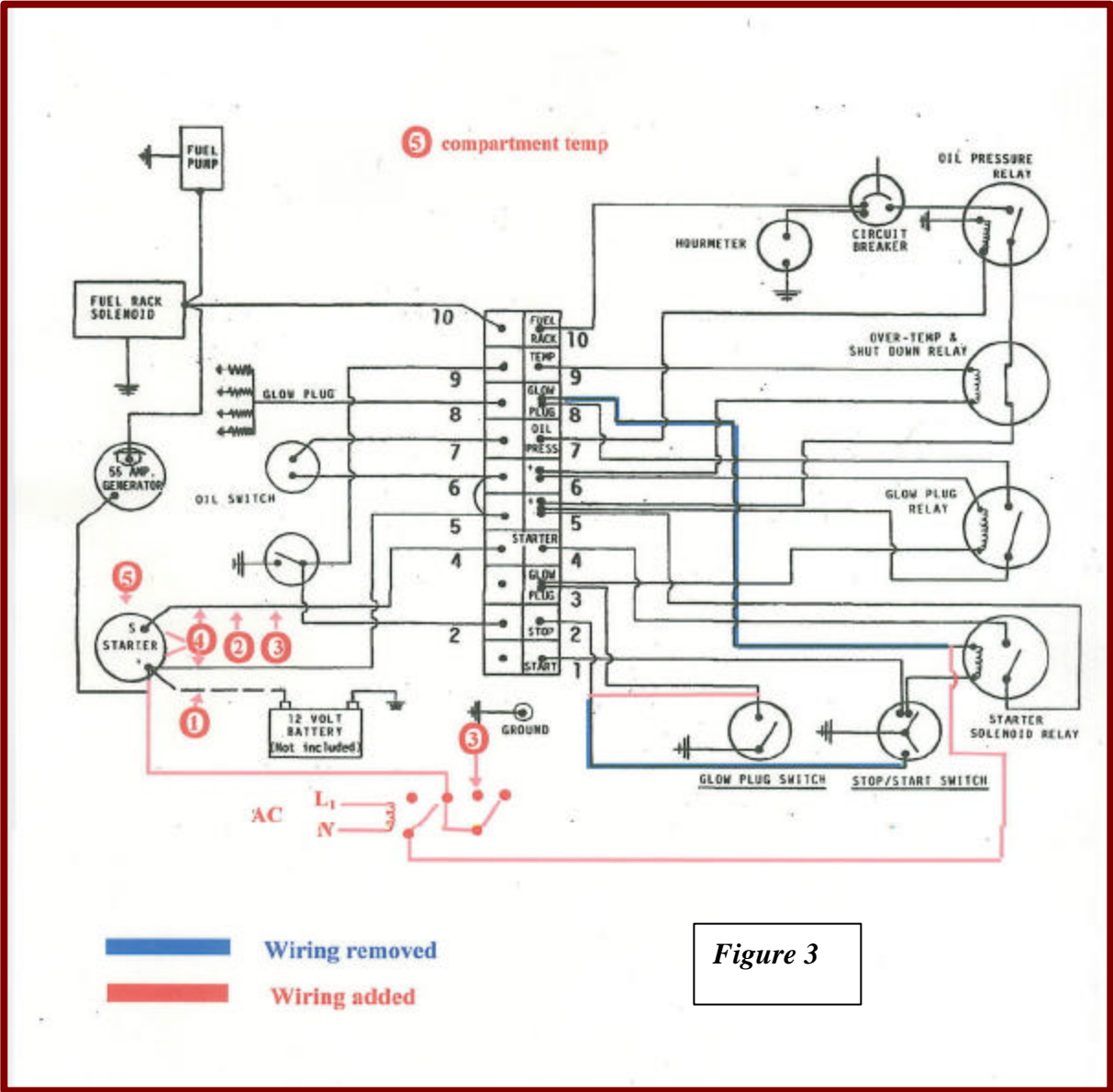

Figure 3

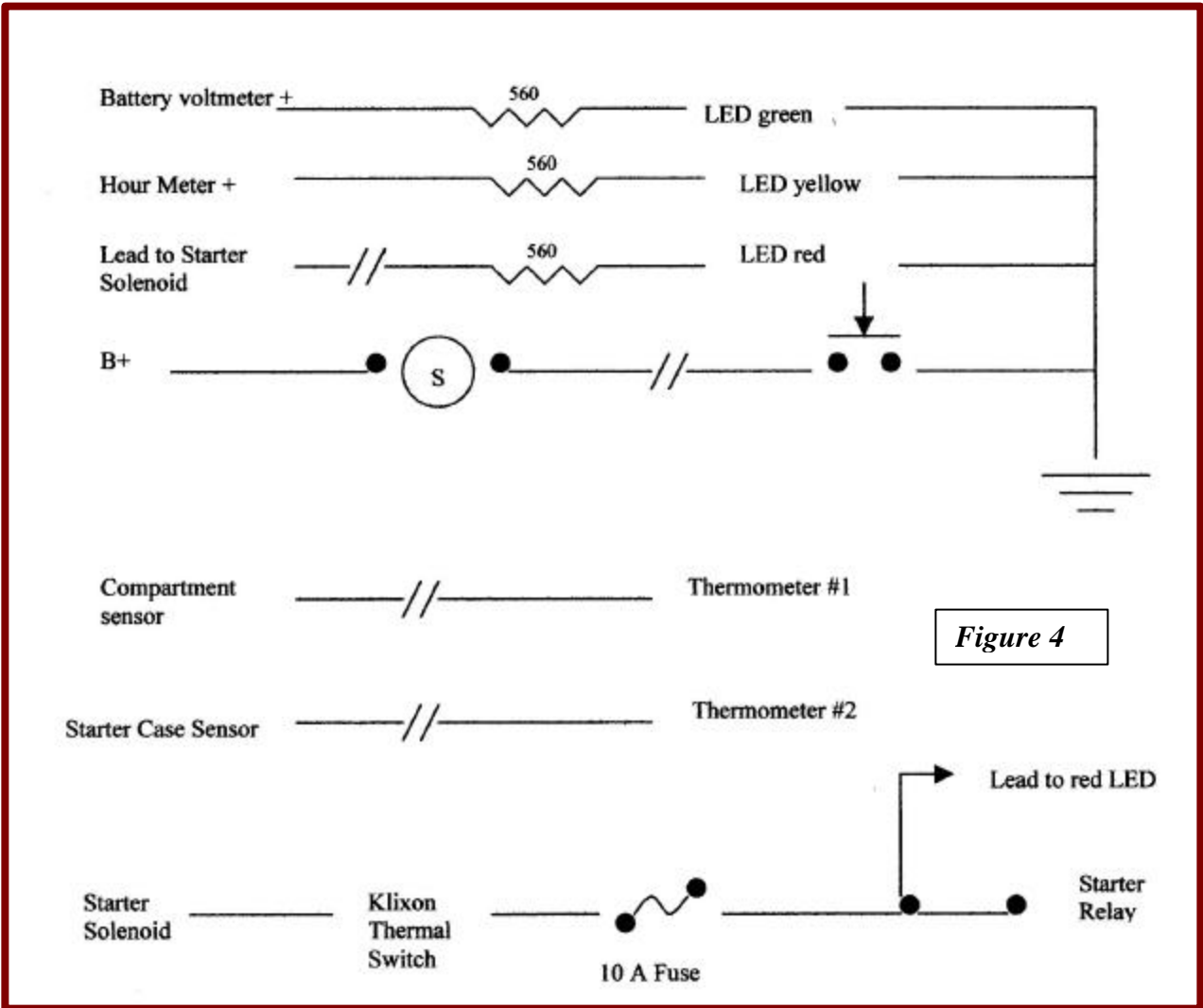

Figure 4