

# ACCESSORY BRAKES

FOR MOTORHOMES

**These devices provided added stopping ability in hilly terrain and added control on flat land or city streets, while also enhancing brake lining and tire life.**

By **CAROL F MAXWELL & ES. GURDJIAN, F76350**

The engine brake, exhaust brake, transmission retarder, and electromagnetic drive-shaft retarder are four types of accessory braking devices used in motorhomes today. These systems enhance stopping ability in both hilly and level terrain. An added benefit is that they help to preserve brake linings and tires. In addition to examining the workings of these devices, it is interesting to explore the history of accessory brakes, which have been in existence for a number of years.

Sarrazin, a French engineer, was granted a patent to use eddy currents as a vehicle retarder in 1926. In 1936 Telma purchased the rights to the patent and began producing the Telma electromagnetic retarder. In August 1961, C. Lyle Cummins Jr. and G.S. Haviland presented a paper titled "The Jacobs Engine Brake, A New Concept In Vehicle Retarders" at the Society of Automotive Engineers (SAE) national West Coast meeting in Portland, Oregon. In this paper, Cummins acknowledged that "the concept of retarding a vehicle by converting an engine into some form of air compressor is not new. Patents dating back at least 40 years show attempts at this." These patents all made use of shifting camshafts and extra cam lobes to change exhaust valve timing. All of them

proved to be unreliable.

Cummins, et al, had begun research and development of an engine brake in 1956. During the same period (1954), the Williams Controls, formerly known as Williams Air Control, developed an exhaust brake. They experimented with butterfly- and guillotine-type valves and ultimately focused on the guillotine, which is still in use today.

The importance of accessory brakes is dramatically demonstrated in data compiled by Telma Retarder Inc. The chart below, provided courtesy of Telma, compares brake surface area to weight ratios. The chart indicates that heavy trucks have almost four times less brake friction area per ton than

still in the shortest possible distance without loss of control, as in emergency stops. Because of design and manufacturing limitations, foundation brakes cannot effectively dissipate the temperatures reached when used repeatedly and for extended periods of time. The foundation brakes of a 15-ton, 4x2 vehicle descending a 12 percent grade, 4.35 miles long, produce enough energy to melt a 463-pound metal casting. On a 6 percent gradient, the foundation brakes of a 19-ton 4x2 vehicle traveling at 40 mph reach 752 degrees Fahrenheit after only 15 seconds. The hotter brake linings get, the less efficiently they perform (up to 60 percent loss of efficiency above 520 degrees Fahrenheit). It will take the

Type of Vehicle	Brake Surface (Sq. In.)	Weight (Tons)	Sq. In./ton
2,202 pound car	117	1	117
8,900 pound truck	223	4	56
14,500 pound truck	330	65	51
37,000 pound truck	750	16.5	45
80,000 pound truck	1,128	36	31

cars.

According to the Telma literature, "Foundation brakes are designed to maintain a vehicle in a stationary position for indefinite periods, as in parking, and to bring the vehicle to a stand

above vehicle 15 minutes at 19 mph to bring the temperature of its brakes down to 392 degrees Fahrenheit.

"When foundation brakes are applied, heat is generated. This heat radiates to the wheels and eventually to

WITHOUT JAKE BRAKE

WITH JAKE BRAKE

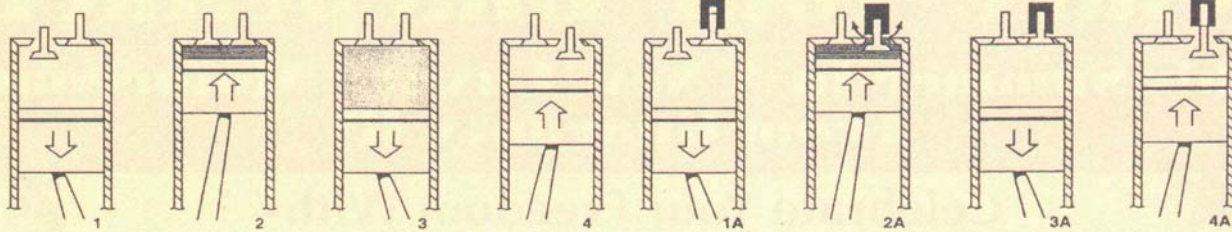

Figure 1: Engine Cycle Without And With Jake Brake

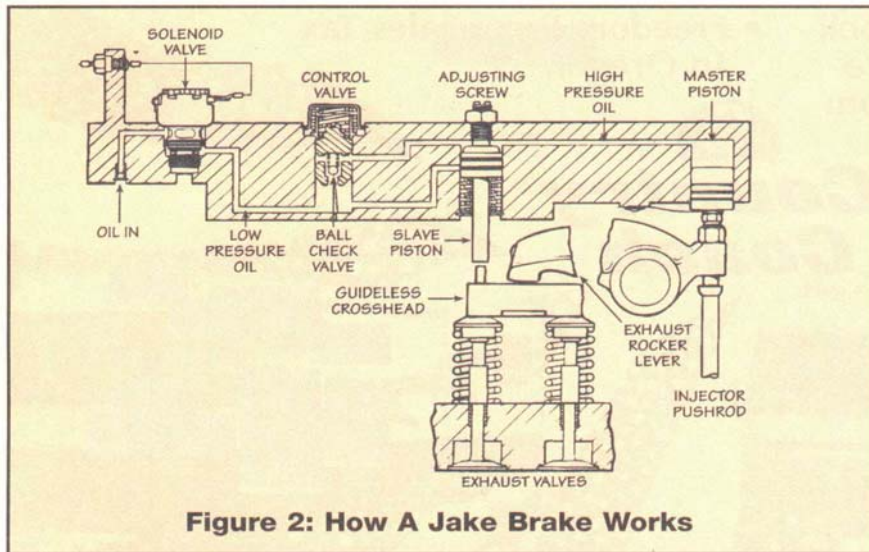

Figure 2: How A Jake Brake Works

the tires, which can result in tire blowouts. Bead temperatures in excess of 250 degrees Fahrenheit for extended periods of time cause burnt tire beads, making remounting operations difficult and tires unfit for retreading. Heat causes tires to run hotter and wear faster. Retarders reduce tire operating temperatures and increase tire life by more than 10 percent for most effective units."

**Engine brake.** Historically, the Jacobs Engine Brake has been very well received. The Jake Brake, as it is known, is ideally suited to large-displacement, heavy-duty diesel engines, although assemblies have to be customized for each engine model. Engine brakes can produce substantially more retarding horsepower than exhaust brakes. In motorhome applications, the Jake Brake is used on the larger Detroit Diesel engines, including the Series 60. Pacbrake Engine Brakes also produces an engine brake for the Series 60 engine.

On V6 and V8 Detroit Diesel two-cycle engines, the engine brake consists of one housing assembly per cylinder. On the V8, two housing assem-

blies are controlled by one solenoid, with the second housing assembly referred to as a drone. The V6 has three housings per solenoid; two are drones. The eight-cylinder applications have four solenoids that usually

sion while obtaining no energy from the power stroke. See Figure 1 for a comparison of what happens without and then with a Jake Brake installed.

In Figure 2, titled "How A Jake Brake Works," note the following components: solenoid, control valve, master piston, slave piston, and exhaust valve bridge (exhaust cross-head). The solenoid can be activated only during a "no fuel" condition. The solenoid allows engine oil to flow through the control valve to the master and slave piston. The master piston is forced down onto the rocker arm of the fuel injector, then the rocker arm pushes the master piston upward. The control valve prevents backflow of the engine oil trapped between the master piston and the slave piston. The slave piston is pushed downward on the exhaust valve bridge, opening the exhaust valves. This allows the compressed air to escape from the cylinder through the exhaust system to the at-

**8V92 Detroit Diesel engines often are equipped with a dash-mounted dual pyrometer that measures the temperature of the gases in both exhaust manifolds. Some consider this gauge unnecessary, but we have found it to be quite valuable. In the event of a Jake Brake malfunction, this instrument can help identify the problem**

are wired in pairs, and each pair is activated separately. The six-cylinder applications have two solenoids, each individually activated. On straight-six applications, there are two or three housings, depending upon engine type, with one solenoid per housing.

In the most simplistic terms, the Jake Brake turns the engine into an air compressor. During a "no fuel" condition (no fuel injected into the cylinders), the exhaust valves are opened just before the power stroke, so the engine does all the work of compress-

mosphere. Figure 3 illustrates this process.

The rocker arm of the fuel injector is used to time the opening of the exhaust valve. Some engines may use other means of timing, such as an exhaust valve rocker arm of another cylinder. The engine brake is capable of producing a brake horsepower effect approximately 85 percent of the rated output of the engine. The higher the rpm, the higher the efficiency.

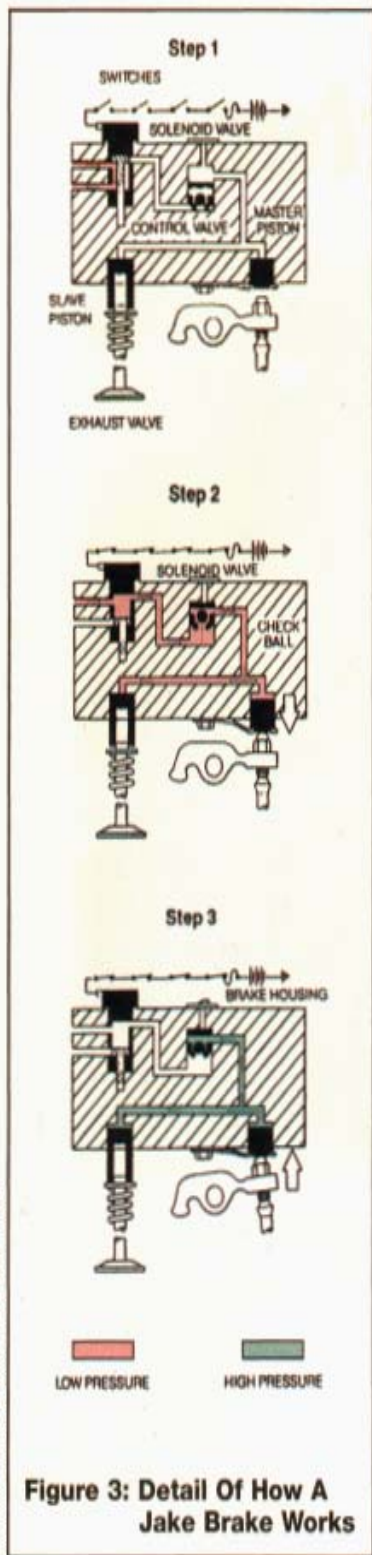
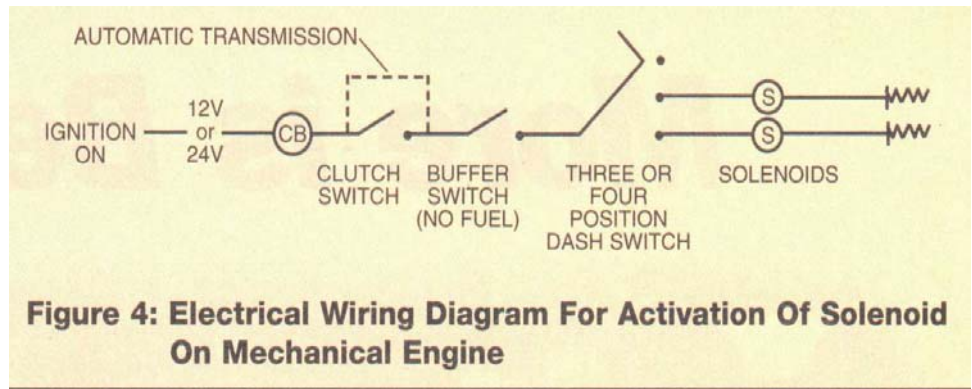

Illustration courtesy of Jacobs Vehicle Equipment Co.

Figure 4 shows the electrical wiring diagram for activation of the solenoid on a mechanical engine. The clutch switch is not used for automatic transmissions. The buffer switch is used to determine the “no fuel” condition in Detroit Diesel Series 71 and 92 mechanical engines. On 8V Detroit engines, a two-position dash switch



allows the activation of either two or four solenoids, which control four or eight cylinders, respectively. On electronic engines, there is a dash module that connects to a Jake Brake control module. The control module is connected to the ATEC ECM (Allison Transmission electronic control, electronic control module) and the DDEC ECM (Detroit Diesel electronic control, electronic control module). There is also provision for a clutch switch on manual transmissions and a pressure switch on some automatic transmissions. 8V engines use a high-mode or low-mode control.

Series 60 engines after serial number 060004455 are Jake Brake ready. Jake Brakes should not be installed on engines with lower serial numbers. Because of space restrictions on some coach chassis, a two-housing Jake Brake kit may be required. In this case, only four of the six cylinders will be used for the retarding effect. These installations will have a two-mode switch — high and low. An installation with three assemblies will have a three-mode switch— high, medium, and low. Prevost coaches utilize three housings with a two-mode switch. All six cylinders are activated in the high mode and four in the low. On DDEC II applications, a dash switch and a control module interface with the DDEC II ECM and the ATEC ECM. In addition, there is also an interface between the engine brake and the WABCO antilock braking system (ABS). On DDEC III applications, the engine brake is controlled by the DDEC III ECM, so no Jacobs control module is required. DDEC III allows simultaneous engine brake capability and cruise control operation. It also interfaces with the WABCO ABS and the World Transmission ECM (WTEC).

To properly integrate the WTEC with the DDEC III, the requirements of both Allison Transmission and Detroit Diesel must be met.

#### Transmission requirements:

- Transmission ECU must be programmed with combined “Engine Brake” and “Preselect Request” plus “Engine Brake Enable” (“Preselect” modifies shift schedule to raise engine rpm for maximum engine brake effectiveness. The standard preselect is 6-4. Some OEMs use 6-5).

- Engine brake enable switch in “on” position.

- Throttle position signal less than 10 percent.

- Transmission must be in lockup.

#### DDEC III requirements for engine brake operation:

- Engine brake enable switch in “on” position.

- 0 percent throttle position.

- Engine must be in “no fuel” condition (no fuel injected into cylinders).

- Engine rpm at minimum of 250 rpm greater than idle rpm.

- If clutch switch input function configured “on,” input must be grounded.

One of the reasons the Jake Brake has been so well received is its durability. The Jake Brake is tuned as part of a standard engine tune-up and usually does not require any additional maintenance. Special tune-up kits are available from Jacobs Vehicle Equipment Company warehouse distributors. While the Jake Brake usually is included as original equipment, it also can be retrofitted to a coach. A retrofit installation would cost between \$2,000 and \$3,000. This includes approximately eight hours of installation time. Of course, any modification problems would increase the cost.

### Using a pyrometer to monitor engine brake performance.

8V92 Detroit Diesel engines often are equipped with a dash-mounted dual pyrometer that measures the temperature of the gases in both exhaust manifolds. Some consider this gauge unnecessary, but we have found it to be quite valuable. In the event of a Jake Brake malfunction, this instrument can help identify the problem. During normal operation, both indicator needles will range from a low of 300 degrees Fahrenheit under no-load, no-fuel conditions, to a high of 1,100 degrees Fahrenheit under full-load, fuel conditions. Depending upon how the engine has been tuned, there may be a slight but constant variation between the left-side and right-side indicators. When the Jake Brake is activated on both sides, the two indicator needles will settle at approximately 500 degrees Fahrenheit. If the Jake Brake is activated on one side only, the needle on the corresponding side will drop only to between 400 degrees Fahrenheit and 500 degrees Fahrenheit, while the needle on the "off" side will drop to approximately 300 degrees Fahrenheit.

If a solenoid should stick in the "on" position, the exhaust valve re-

Once recognized, you can attempt to temporarily alleviate the condition by releasing the accelerator and manually turning off the Jake Brake. You can then try to fuel the engine again while watching the pyrometer. If the pyrometer needles remain equalized, the attempt was successful. If the solenoid problem persists, you should seek professional advice as soon as possible. If one or both Jake Brake solenoids on one side release prematurely or stop functioning, the temperature on that side will be lower than the opposite side. Not only does the pyrometer indicate that a problem exists, it also indicates which side is malfunctioning.

We learned this from our own experience with an intermittently sticking solenoid that presented the conditions described above. We had asked numerous service personnel what they thought these conditions meant. We were told everything from stuck injectors to some sort of turbo problem. No one, however, suggested a sticking solenoid. Some said to start replacing parts until the problem was resolved, but we were not satisfied with a "hit or miss" approach. Ultimately, we isolated the problem by alternately disconnecting the two solenoids on the

parity between the left-side and right-side temperatures when the Jake Brake was activated. It is important to remember that other conditions, such as injector or linkage problems, may cause changes in the pyrometer readings.

**Exhaust brake.** Initially, exhaust brake performance was limited by the engine manufacturers' specification for maximum allowable back pressure. Exhaust brakes currently supplied on small displacement diesel engines have benefited from engine manufacturers using valve springs with higher tensions, which allow greater back pressure.

The exhaust brake unit is inserted in the exhaust system just after the turbocharger, and in the case of Pacbrake is mounted directly to the turbo. The valve body consists of a round chamber containing a butterfly or guillotine valve, activated by an air cylinder, vacuum cylinder, or electric solenoid. The installation kit includes two exhaust flanges that are welded to the existing exhaust pipe. For after-market installations, a section of the existing exhaust pipe is removed and the flanges are welded to the cut ends. The brake assembly is then held in place using two exhaust clamps. Each manufacturer has its recommended location for installation.

In an air-equipped coach, the valve is activated by an air cylinder that is controlled by an electric air solenoid. In a coach without air, the valve may be activated by a small air compressor or directly by an electric solenoid or vacuum cylinder. The exhaust brake may be activated manually by a foot switch (see Figure 5) or a hand lever. It may also be activated automatically by a fuel pump switch enabled in the "no fuel" condition (see Figure 6). If the coach has a World Transmission, there should be an interface between the exhaust brake and the World Transmission ECM. This interface indicates to the transmission that the exhaust brake is activated and directs it to choose one of the predetermined downshift schedules.

Performance is determined by engine rpm and back pressure. It is desirable to achieve maximum back pressure without exceeding manufacturers' specifications. The various techniques used to meet these parameters include using a back pressure

mains open during the power stroke. The pyrometer reflects this condition by showing a rapid temperature rise on the affected side, which is greatly disproportional to the normally functioning side. You may note a puff of black smoke from the exhaust pipe. If allowed to persist, this condition can cause serious damage to the exhaust valves.

affected bank. One created the high-temperature condition, and the other did not. We initially replaced the solenoid "O" rings, which did not solve the problem. Subsequent replacement of the malfunctioning solenoid produced trouble-free performance.

On another occasion, we were able to diagnose a broken wire to one of the solenoids because there was a dis-

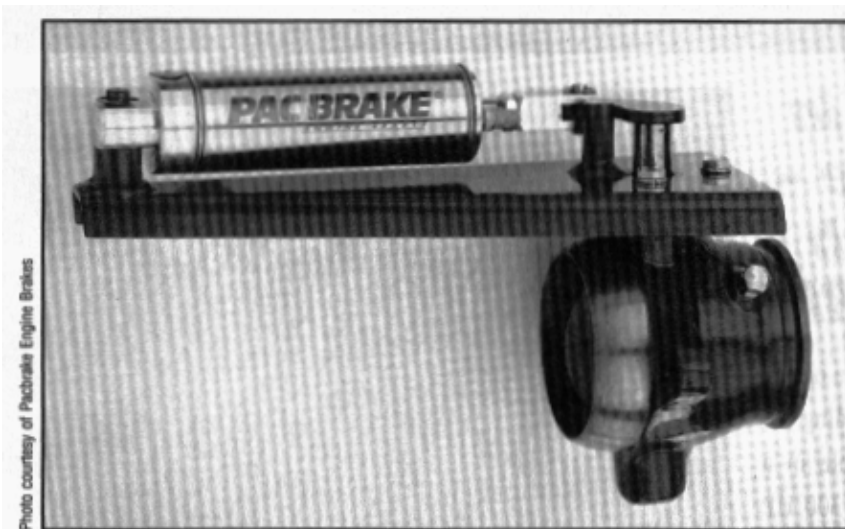

Photo courtesy of Pacbrake Engine Brakes

gauge and a pressure switch to open the valve when limits are exceeded. Brian Roth of BD Engine Brake reports that his company's kits all contain brake pressure gauges and a pressure limiting switch. BD officials have noticed on their gauges that even if heavy-duty valve springs are installed, pressures can exceed their higher specifications. BD has designed a stainless-steel offset butterfly; as engine back pressure climbs, the butterfly gradually opens to maintain high pressure. Thus, the back pressure is the same at 2,000 rpm as at 2,500 rpm. Other methods use a small relief aperture specifically sized for the intended engine application, or an adjustment screw to prevent the butterfly valve from closing completely. This screw is adjusted to maximum allowable back pressure.

The exhaust brake's basic assembly is adaptable to numerous diesel engines. Smaller engines frequently are paired with the Allison World Transmission, which can provide a sequential downshift from sixth to second or sixth to fourth. This increases the engine rpm to effect greater brake horsepower. Performance is also maximized by the lockup feature of the torque converter in the World Transmission.

The exhaust brake is usually original equipment, but it can be retrofitted. Engine manufacturers will have specific recommendations concerning maximum exhaust pressure and valve spring tension. Heavy-duty springs are available for Cummins B5.9 and C8.3 engines only. No spring change is required for Caterpillar 3208T, 3116, and 3126 engines, or for Detroit Diesel 8.2 and the new Series 40 engines. The retrofit cost is approximately \$1,500, including installation.

Exhaust brake manufacturers include Pacbrake Manufacturing, Jacobs Vehicle Equipment Company, BD Engine Brake, Decelomatic, U.S. Gear, and Williams Controls Inc.

**Exhaust brake for gasoline engines.** The Telma chart showing the ratio of brake surface area to vehicle weight indicates that a 14,500-pound vehicle has half the braking surface area per ton as compared to a car. We take this to indicate that even small Class A motorhomes will benefit from an accessory braking device. We have driven a 16,000-pound motorhome

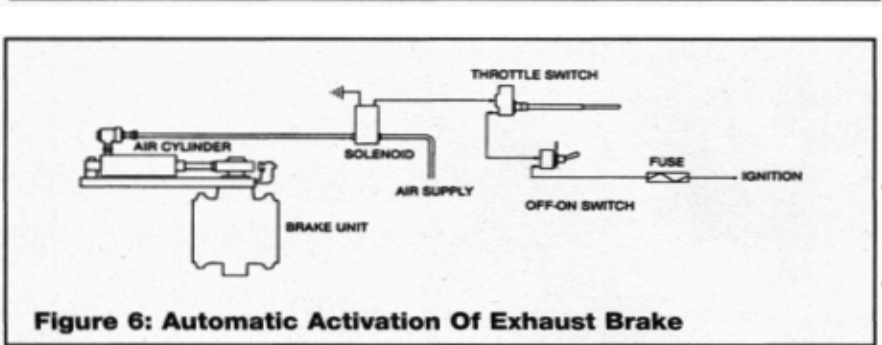
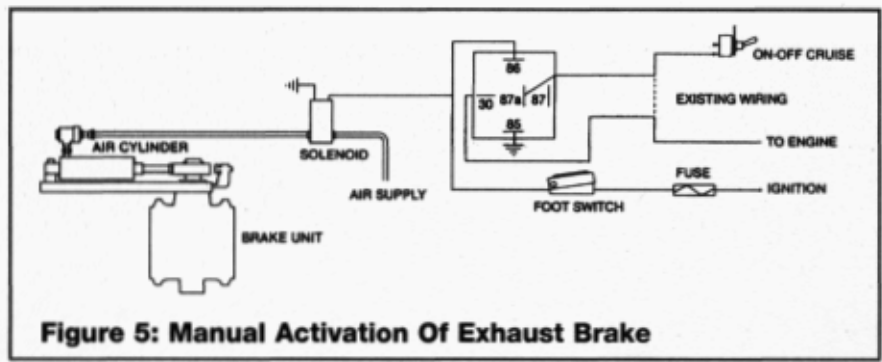

(plus a towed car) with only service brakes and have some not-so-fond memories of navigating 8 percent grades as slowly as possible with the brakes squealing all the way down. Decelomatic Corporation has been installing exhaust brakes since 1968. The company uses the Williams valve for diesel engines, and it manufactures and installs the "Mountain Tamer," the only exhaust brake available for gasoline engines.

Some experts believe that a gasoline engine, transmission, and driveline components are not strong enough to provide prolonged durability with the use of accessory braking devices, because the maximum allowable back pressure of a gas engine is significantly lower than that of most diesel applications. Louis King, president of Decelomatic, responds that, "Exhaust braking is not related to compression ratio but only to the strength of the exhaust valve springs. For instance, a Ford diesel 7.3-liter and a Ford 460-cid gas engine both have nearly the same exhaust valve spring load and both produce approximately thirty-five psi of retarding pressure. A stronger valve spring is available for the gas engine for racing applications but is very rarely needed or used for added retarding capacity." King continued, "Gasoline exhaust systems are designed for over 100 psi backfire pressure. The hardest thing on an exhaust system is sudden cooling from a high-heat condition causing warping and

cracking. Exhaust compression heat prevents this sudden cooling."

In regard to using an exhaust brake without a lockup automatic transmission, King said, "In the design speed range of a particular gear, the automatic transmission without lock-up is ninety percent to ninety-five percent torque efficient. Adding lockup may add up to five percent more torque efficiency. The secret is to use the proper gear for descending. It is also as important on the ascent. Proper gear selection is required to prevent slip and attendant overheating for both ascent and descent." More than 3,000 gas-powered vehicles have been equipped with the Mountain Tamer. The company policy is to honor any claims of damage to the engine caused by the exhaust brake valve during the vehicle warranty period. Incredibly, King notes that not a single claim has been submitted. According to King, "To provide maximum retarding pressure with existing exhaust valve springs, Decelomatic utilizes a gate valve to obtain good sealing over a long life in the presence of exhaust deposits. The gate valve has several features. It provides one hundred percent removal of the closure from the exhaust flow path, thereby assuring zero pressure loss. It provides inherent self-cleaning of the sealing surface. It can be simply designed to fail open to assure continued vehicle operation. It can be one hundred percent enclosed to protect working parts from road

Illustrations courtesy of Pacbrake Engine Brakes

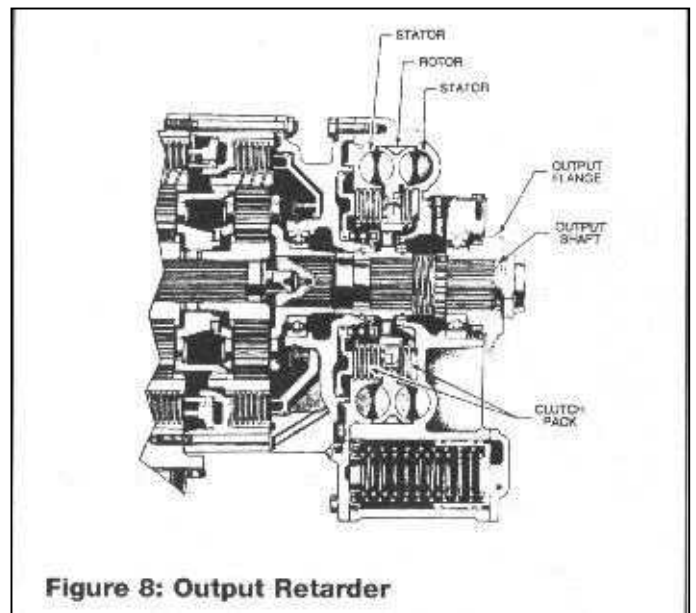
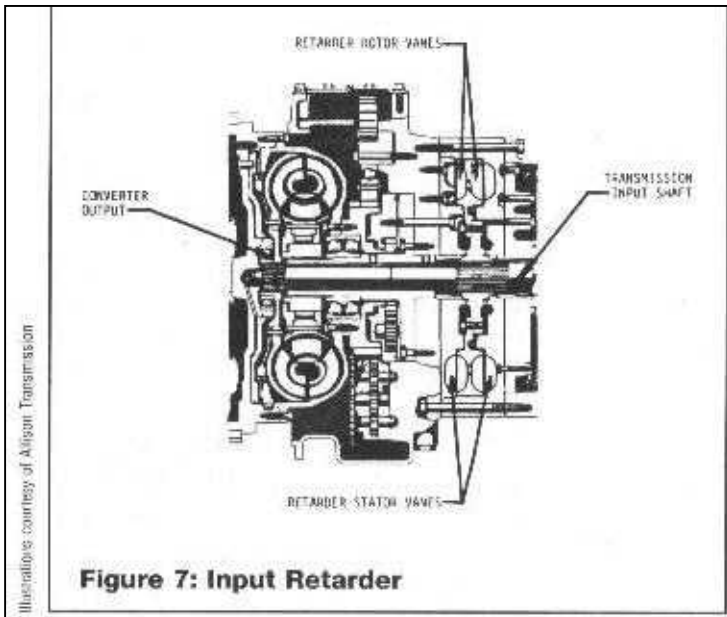

grime, sand, dust, mud, and salt. To obtain maximum supplemental braking from the Mountain Tamer, an optional shift kit can be installed in the automatic transmission. This permits a manual shift from three to one at any speed, which has the capacity for a real neck-popping deceleration without overrevving the engine. This is called our Drop Anchor kit and retails for approximately three-hundred-fifty dollars. Another popular optional feature is the variable braking control. This enables the driver to “tune in” the downhill speed to match the traffic flow.” Exhaust brakes for gasoline engines appear to be effective and do not seem to be associated with engine component failures. The exhaust brake valve requires some maintenance at engine oil change intervals. With the elimination of lead in gasoline and with today’s cleaner-burning fuels, exhaust contamination problems have lessened. The valve(s) can be installed on pre-electronic engines with ease. When installing an exhaust brake on a post-1989 gasoline engine, it is important to maintain engine computer and emission standards integrity. The total cost of adding a Decelomatic Mountain Tamer to a gasoline engine is approximately \$3,000.

**Transmission retarder.** The basic components of a transmission retarder are the rotor, stator, retarder housing, and control valve body. The orientation of these components to the transmission will determine whether it is an “input” or “output” retarder. The rotor is splined to either the input or output

shaft and rotates at the speed of the shaft. The rotor of the input retarder rotates at engine speed. The rotor of the output retarder rotates at driveshaft speed. The rotor, the retarder housing, and the stator are vaned. (See figures 7 and 8.)

The valve body controls the flow of transmission fluid in and out of the retarder. To initiate the retarding process, transmission fluid fills the stator and retarder housing. The rotor vanes move the fluid while the stationary vanes of the stator and retarder housing resist the motion. This action creates friction and heat as it slows the rotor and shaft. The heat is dissipated via the transmission fluid as it circulates through the transmission cooling system. To stop retardation, the transmission fluid is allowed to flow out of the retarder housing and the rotor moves freely.

The Allison HT 700 Series offers either an input or output retarder. It is not possible to equip a transmission with both retarders simultaneously. The input retarder is particularly well-suited for vehicle downhill speed control, and the output retarder is particularly well-suited for stop-start duty cycles. Either retarder significantly increases the heat load, and any vehicle with a retarder must have an upgraded transmission cooling system to achieve satisfactory heat dissipation. A hand lever, foot switch, or a combination hand lever and pneumatic control are available options for activating the valve body to initiate retardation. The combination control, shown in

Figure 9, provides automatic operation to a predetermined level of retardation when the engine is in a “no fuel” condition.

The Allison World Transmission (WT) series can be equipped only with the output retarder. It also has an accumulator to maintain a reserve amount of transmission fluid for quickly filling the retarder housing. (See Figures 10 and 11.) The output retarder functions similarly to the input retarder. Its rotor is splined to the output shaft and always rotates at drive-shaft speed. Retarder capacities are shown below:

The retarder electronic controls include the ECU, a resistance module, two solenoids, and a retarder temperature sensor. The ECU controls all the functions of the transmission and the retarder. The resistance module converts a signal generated by the retarder apply device into a signal that the ECU can recognize. One of the solenoids controls application of vehicle air pressure to the accumulator, and the second controls the retarder control regulator valve. The retarder temperature sensor sends retarder temperature information to the ECU. There are two versions of software to handle over-temperature conditions. Inputs to the ECU include retarder enable, service brake status, and anti-lock brake response. These inputs, along with numerous others, are used for adaptive shift logic in the ECU to continuously optimize shift quality. Outputs from the ECU are retarder indicator and retarder temperature

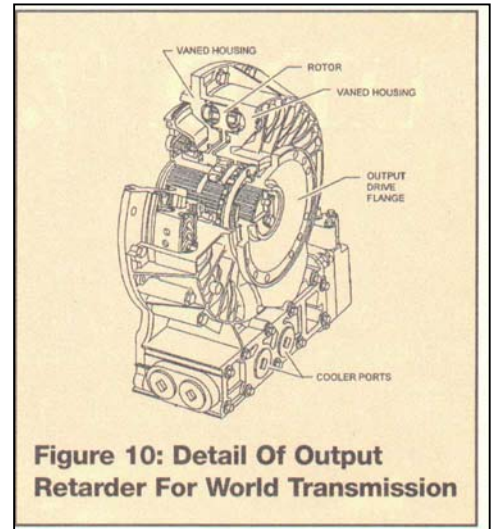
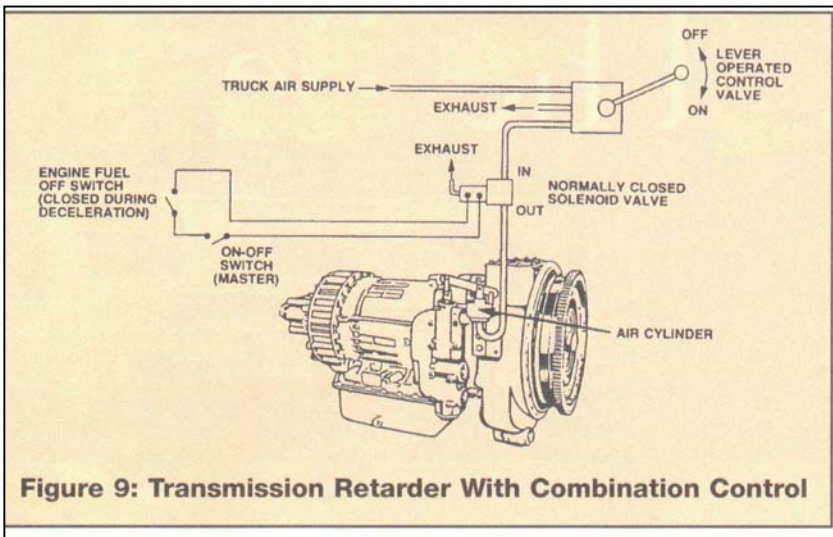

**Figure 10: Detail Of Output Retarder For World Transmission**

indicator. There are several methods of activating the WT output retarder. A hand lever or foot pedal can be set at different positions that send a varied 5-volt signal to the ECU. The ECU interprets this signal and determines the level of retardation. The hand lever is a six-position lever that allows adjustment from zero to 100 percent retarding capacity. This feature provides a flexibility that many motorhome owners find desirable.

A "Pressure Switch" option integrates retarder activation with the vehicle service brakes. Up to three switches can be connected to the service brake system to provide one to three distinct levels of retardation. All switches are normally open and close

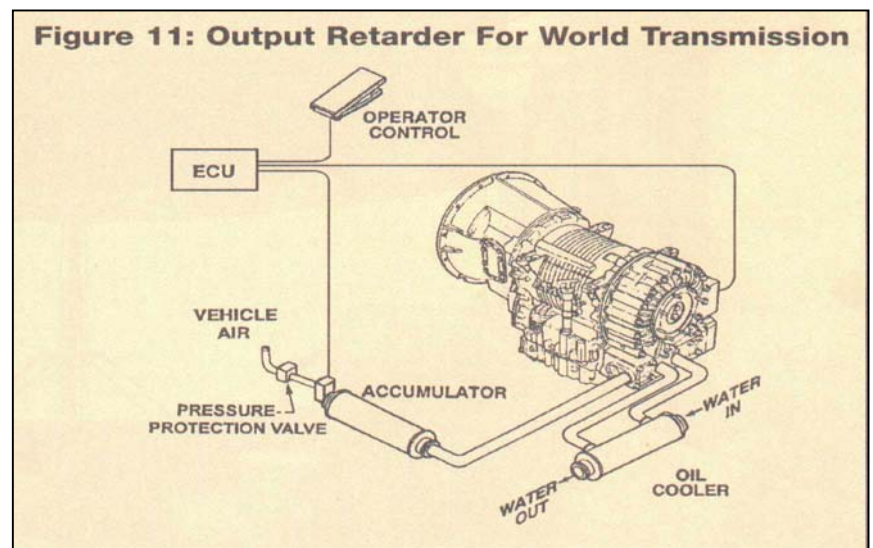

**Figure 11: Output Retarder For World Transmission**

### RETARDER CAPACITIES

WT retarders are available in three different capacities: low, medium, and high. Maximum retarder capacity is determined by the spring under the retarder control valve located in the retarder control valve body.

MD retarders are capable of absorbing the following torque and horsepower output:

Capacity	Power	Torque
Low	298 kw (400 hp)	1,356 Nm (1,100 lb ft)
Medium	373 kw (500 hp)	1,898 Nm (1,300 lb. Ft)
High	447 kw (600 hp)	2,170 Nm (1,600 lb ft)

HD retarders are capable of absorbing the following torque and horsepower output:

Capacity	Power	Torque
Low	373 kw (500 hp)	1,763 Nm (1,300 lb ft)
Medium	447 kw (600 hp)	2,170 Nm (1,600 lb ft)
High	447 kw (600 hp)	2712 Nm (2,000 lb ft)

dependent on the switch's calibration. They are available in four different pressure settings (2, 4, 7, and 10 psi) and are non-adjustable.

The "Auto Apply" option has two capabilities. The "Auto Full On" option allows the ECU to command the retarder "Full On" when the "Retarder Enable" switch is activated and the throttle is closed with the transmission output speed above a preset value. The "Auto Half On" is the same as "Auto Full On," except the ECU commands the retarder "Half On." "Auto Half On" is available only in combination with another control device that provides for "Full On" capabilities.

Any two of the previously mentioned retarder apply controls can be installed in the same vehicle. A combination of controls allows greater flexibility in applying the retarder. The transmission retarder is compati-

ble with antilock braking systems

Electromagnetic retarder. Telma is the world leader in electromagnetic retarders. Figure 12 illustrates the components of the Telma retarder. It has two rotors and a stator, with the rotors separated from the stator by small air gaps. The stator contains eight electromagnetic coils that are activated in pairs to allow four stages of retardation. Telma manufactures models that can be installed in a mid-drive location or as an integral part of the transmission or drive axle assembly. Figure 13 shows a Telma-equipped RS-24-160 axle.

Electrical current flowing through the stator coils produces magnetic fields of alternate polarities. As the rotors pass through these fields, eddy currents are generated. The currents slow the rotors, the attached drive shaft(s), and the drive wheels. There is no friction on the moving parts, braking loads are not carried by the clutch/transmission internal components, and the heat generated during braking is self-dissipated by the rotors as they rotate. The degree of retardation is not affected by speed, engine rpm, or type of transmission. The effect is also the same regardless of whether the transmission has a lockup torque converter.

The Telma retarder is extremely powerful with brake horsepower between 130 and 1,170 depending on the retarder. Its operation is quiet, with full activation within 120 milliseconds of retarder control activation. Full deactivation occurs within 120 milliseconds to avoid parasitic loading to the vehicle during acceleration or

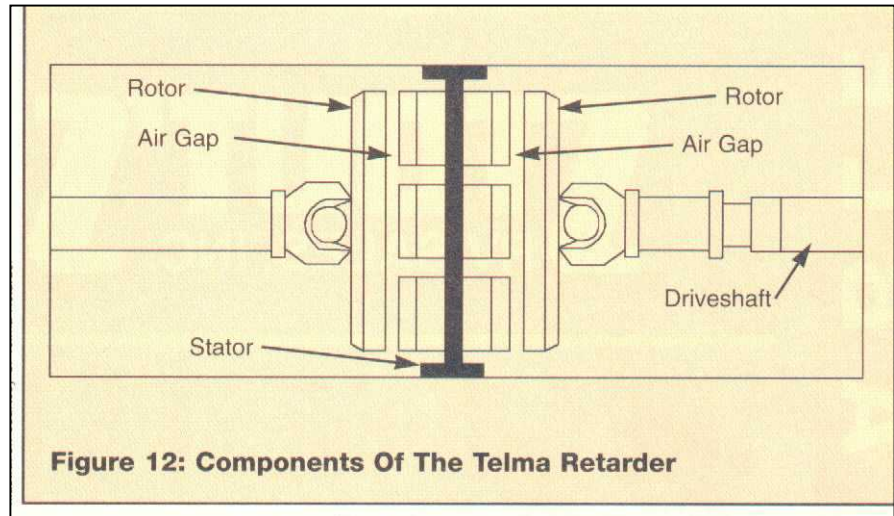

**Figure 12: Components Of The Telma Retarder**

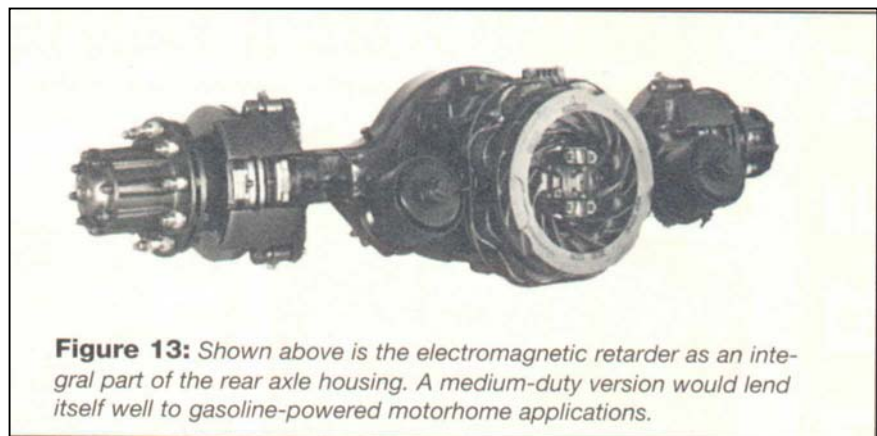

**Figure 13:** Shown above is the electromagnetic retarder as an integral part of the rear axle housing. A medium-duty version would lend itself well to gasoline-powered motorhome applications.

Telma has an extensive product line to precisely match the retarding needs of each application. This includes vehicles ranging between 6,000 and 100,000 pounds. The retarder units weigh between 137 and 700 pounds. Retarders for motorhome ap-

of water weigh 450 pounds.

The Telma retarder can be controlled with either a hand control, brake pedal, or both. As mentioned earlier, retardation occurs in four stages, and full retardation is achieved before service brakes are applied. A dashboard display of four lights indicates the level of retardation. An automatic switch disengages the retarder when the vehicle comes to a stop.

We had the opportunity to drive a highway coach equipped with a Telma retarder and were favorably impressed with its performance. The Telma is used in a variety of applications, including long-haul trucks, transit buses, ambulances, fire trucks, and refuse trucks. It can be used with either diesel or gasoline engines and can be retrofitted.

Precise alignment of the drive shaft is critical, so it must be installed by an authorized service center. Since there is no friction or moving parts,

---

**Accessory braking devices greatly improve vehicle safety. Reliability and durability of service brakes are increased, and maintenance dollars are saved by increasing the life of brake linings and tires. Anyone who has driven a motorhome equipped with an accessory brake is not likely to give up this option willingly.**

---

the vehicle during acceleration or coasting and to avoid any interference with the proper functioning of antilock braking systems.

plications usually weigh between 300 and 500 pounds. To keep weight in perspective, remember that 50 gallons

the only maintenance is bearing lubrication every 24,000 miles. The capacity of the vehicle's electrical system may have to be increased by upgrading to a high-output alternator or upgrading the batteries. The cost of retrofitting a Telma retarder is between \$4,000 and \$6,000.

**Summary.** Accessory braking devices greatly improve vehicle safety. Reliability and durability of service brakes are increased, and maintenance dollars are saved by increasing the life of brake linings and tires. Anyone who has driven a motorhome equipped with an accessory brake is not likely to give up this option willingly. While other coaches plunge down the mountainside at frightening speeds, those with an accessory brake tame the treacherous terrain. Even on flat land or city streets, the device improves control by increasing the available braking ability.

In today's market, many diesel-powered motorhomes come equipped with an accessory braking device. Those that are not so equipped can be retrofitted.

Any retrofit must be carefully planned considering the recommendations of the engine and transmission manufacturers. The consumer should have thorough knowledge of the component manufacturers' warranty and who is responsible should any damage occur to the transmission, engine, or driveline components.

#### **Further Info**

The following companies and individuals provided information and/or illustrations for this article:

#### **Allison Transmission**

P.O. Box 894  
Indianapolis, IN 46206-0894  
(800) 252-5283  
David Wheatley

#### **BD Engine Brake**

Unit A10, 33733 King Road  
Abbotsford, British Columbia  
Canada V2S 4N2  
(604) 853-6096  
Brian Roth

#### **Decelomatic Inc.**

4837 Indian School Road  
Phoenix, AZ 85018  
(602) 956-8200  
Louis King

#### **Jacobs Vehicle Equipment Company**

22 E. Dudley Town Road  
Bloomfield, CT 06002  
(203) 243-7635  
Bill Werner and David Pearman

#### **Martin Diesel Inc.**

P.O. Box 1000  
Defiance, OH 43512  
(419) 782-9911  
Jim Martin

#### **Pacbrake Engine Brakes**

P.O. Box 1822  
250 H St.  
Blaine, WA 98231 -1 822  
(800) 663-0096  
Bruce Sebring and Kevin McKilligan

#### **Telma Retarder Inc.**

3488 Diablo Ave.  
Hayward CA 94545  
(510) 784-1048  
Tell Adams